

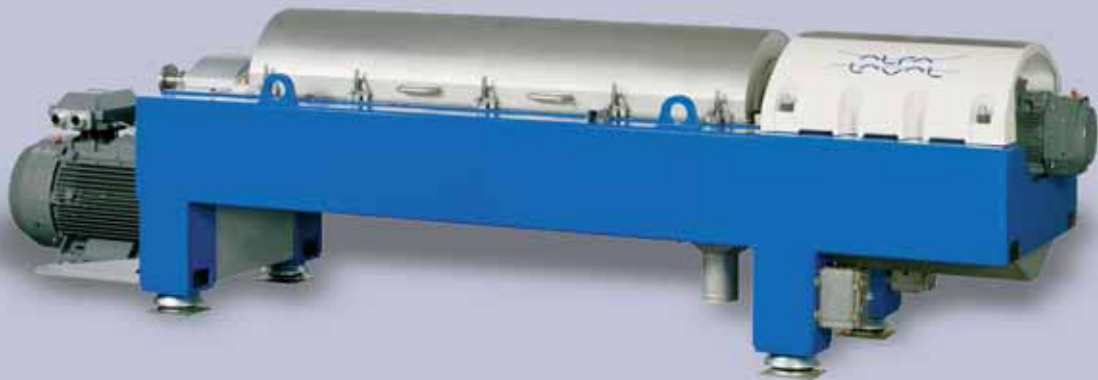

LYNX 35

Decanter centrifuge for cost-effective slop oil treatment



Optimizing slop oil treatment

The Alfa Laval LYNX 35 decenter centrifuge is the preferred solution when selecting three-phase equipment for slop oil treatment.

By using centrifugal force of more than 3,500 G, the LYNX 35 is able to separate high-density oil from water, and deliver liquids of a clarity never before available using decenter centrifuges. The availability of online inter-phase adjustment, with no need for mechanical components, makes it easy to optimize the quality of the separated oil and water phases.

The combination of these high G-forces and Alfa Laval experience in the field of slop oil treatment make it possible for the LYNX 35 design to efficiently remove most of the fine particles and deliver the driest possible solids.

Features and benefits

- Torque control
- Higher G-force
- Greater centrate clarity
- More efficient particle separation
- Specially designed bowl geometry
- 360° solids discharge port
- Online inter-phase adjustment
- Available in configurations that comply with NEMA and ATEX regulations.

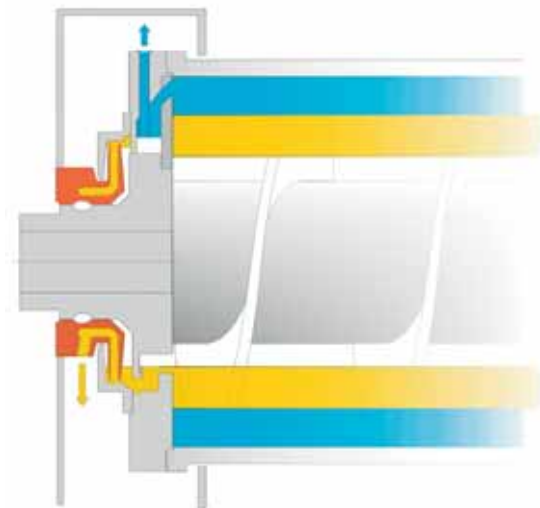
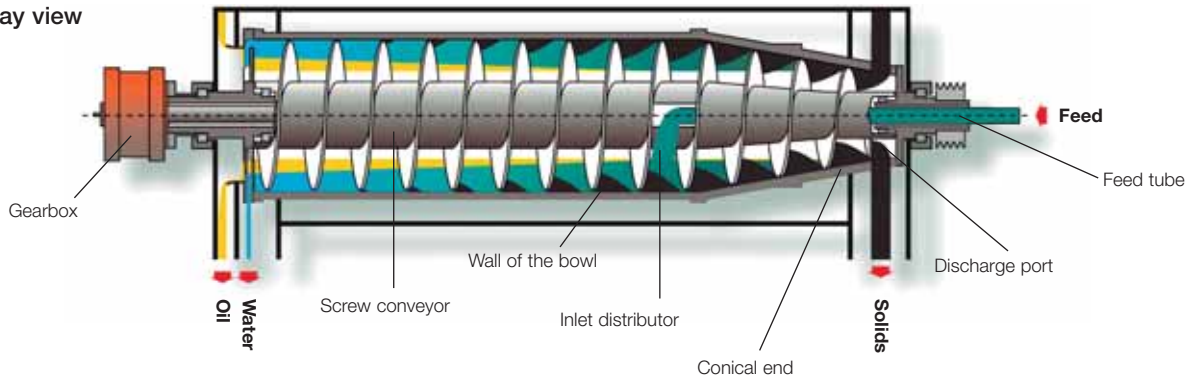

Fig. 1: Liquid discharge with online interphase adjustment

Cutaway view



Principle of operation

The LYNX 35 is a decanter centrifuge that features a slender cylindrical bowl with a relatively large length/diameter ratio, and a conical end. This bowl rotates at speeds of up to 3650 rpm, producing centrifugal force of anywhere from 300 to 3574 G. A screw conveyor fitted inside the bowl ensures the continuous removal of the separated solids.

The feed is led into the bowl through a stationary inlet tube and then smoothly accelerated by an inlet rotor. Centrifugal force causes instant sedimentation of these solids on the wall

of the bowl. The screw conveyor rotates in the same direction as the bowl, but at a different speed, and thus transports the solid phase of the slop oil to the conical end. These solids are then lifted clear of the liquid, and the capillary liquid is then drained centrifugally, before being discharged into the casing through the solids discharge port.

Separation into two liquid phases takes place over the entire length of the cylindrical part of the bowl, and the clarified heavy and light liquid phases are discharged from the bowl by flowing over two sets of level tubes.

Technical data

Water flow*	1 – 15 m ³ /h (4-66 GPM)
Oil flow*	1 – 10 m ³ /h (4-44 GPM)
Solids flow*	1 – 5 m ³ /h (4-22 GPM)
Maximum speed	3,650 rpm
Centrifugal force up to	3,574 G
Differential speed range	2-40 rpm
Solids capacity	Up to 12 ton/h (26,000 lbs)
Main power	90 kW (125 Hp)
Backdrive power	15 kW (20 Hp)
Dry weight of decanter unit	5,000 kg (11,000 lbs)

*Typical values, contact Alfa Laval for details.

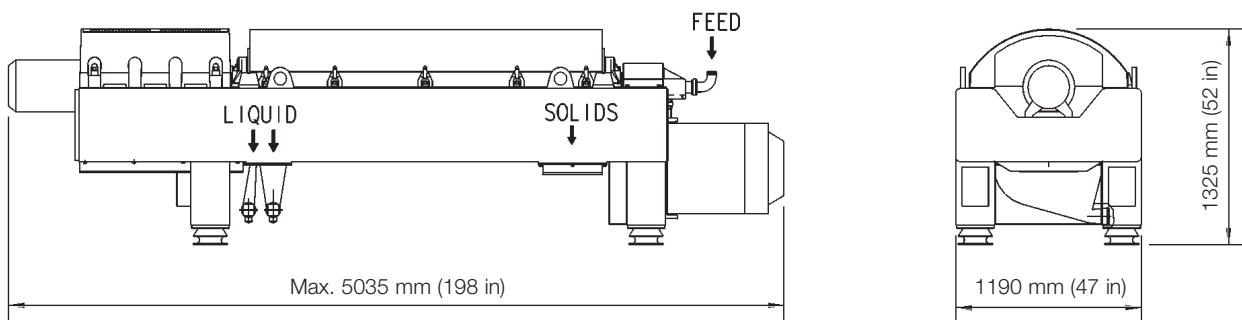

How to contact Alfa Laval

Up-to-date Alfa Laval contact details for all countries are always available on our website at www.alfalaval.com